

# **SCAG**

## **POWER EQUIPMENT**

# ***OPERATOR'S MANUAL***

## **Striper**



**Models:**    **SZL, SFZ, SFZP, SPZ, SCZ48/52  
STRIPER**

**STC, STCII, SCZ61/72, STT, STTII  
STRIPER**

This manual contains the operating instructions and safety information for your Scag mower accessory. Reading this manual can provide you with assistance in maintenance and adjustment procedures to keep your mower performing to maximum efficiency. The specific models that this book covers are listed on the inside cover. Before operating your machine, please read all the information enclosed.



# WARNING

## FAILURE TO FOLLOW SAFE OPERATING PRACTICES MAY RESULT IN SERIOUS INJURY OR DEATH.

- Read this manual completely as well as other manuals that came with your mower.
- DO NOT operate on steep slopes. To check a slope, attempt to back up it (with the cutter deck down). If the machine can back up the slope without the wheels slipping, reduce speed and use extreme caution.
- Under no circumstances should the machine be operated on slopes greater than 15 degrees. ALWAYS FOLLOW OSHA APPROVED OPERATION.
- Stay two cut widths away from slopes, drop offs, ditches and retaining walls.
- DO NOT mow on wet grass. Wet grass reduces traction and steering control.
- Keep all shields in place, especially the grass discharge chute.
- Before performing any maintenance or service, stop the machine and remove the spark plug wire and ignition key.
- If a mechanism becomes clogged, stop the engine before cleaning.
- Keep hands, feet and clothing away from power-driven parts.
- Keep others off the mower (only one person at a time)

## REMEMBER - YOUR MOWER IS ONLY AS SAFE AS THE OPERATOR!

HAZARD CONTROL AND ACCIDENT PREVENTION ARE DEPENDENT UPON THE AWARENESS, CONCERN, PRUDENCE, AND PROPER TRAINING OF THE PERSONNEL INVOLVED IN THE OPERATION, TRANSPORT, MAINTENANCE, AND STORAGE OF THE EQUIPMENT.

This manual covers the operating instructions and illustrated parts list for:

SZL36 STRIPER	with a part number of	923M
SZL, SFZ, SFZP, SPZ, SCZ-48/52 STRIPER	with a part number of	923F
STC, STCII, SCZ-61/72, STT, STTII STRIPER	with a part number of	923G

Always use the model number and part number when referring to this product.

## Table of Contents

<b>SECTION 1 - GENERAL INFORMATION.....</b>	<b>1</b>
1.1 INTRODUCTION.....	1
1.2 DIRECTION REFERENCE .....	1
1.3 SAFETY AND OPERATING INSTRUCTIONS .....	1
<b>SECTION 2 - ASSEMBLY INFORMATION.....</b>	<b>2</b>
2.1 ASSEMBLY.....	2
2.2 ASSEMBLY INSTRUCTIONS - SZL / SFZ / SFZP / SPZ.....	2
2.3 ASSEMBLY INSTRUCTIONS - STC / STCII.....	3
2.4 ASSEMBLY INSTRUCTIONS - SCZ48/52 .....	4
2.5 ASSEMBLY INSTRUCTIONS - SCZ / SCZII 61/72 .....	5
2.6 ASSEMBLY INSTRUCTIONS - STT / STTII.....	6
<b>SECTION 3 - OPERATING INFORMATION .....</b>	<b>8</b>
3.1 OPERATING INSTRUCTIONS .....	8
<b>SECTION 4 - ILLUSTRATED PARTS LIST .....</b>	<b>11</b>
SZL36 STRIPER ASSEMBLY .....	12
SZL / *SFZ - 48/52/61 STRIPER ASSEMBLY .....	14
*SFZ / SFZP / SPZ STRIPER ASSEMBLY.....	16
STC / STCII / STWC STRIPER ASSEMBLY .....	18
SCZ - 48/52 STRIPER ASSEMBLY.....	20
SCZ / SCZII - 61/72 STRIPER ASSEMBLY .....	22
STT / STTII STRIPER ASSEMBLY .....	24
LIMITED WARRANTY- COMMERCIAL ACCESSORY .....	27



## GENERAL INFORMATION

### 1.1 INTRODUCTION

This manual has been prepared to provide the information you need to correctly assemble, operate, and maintain this Striper Accessory. Read it carefully and keep it for future reference.

**THE REPLACEMENT OF ANY PART ON THIS PRODUCT BY OTHER THAN THE MANUFACTURER'S AUTHORIZED REPLACEMENT PART MAY ADVERSELY AFFECT THE PERFORMANCE, DURABILITY OR SAFETY OF THIS PRODUCT.**

**USE OF OTHER THAN ORIGINAL SCAG REPLACEMENT PARTS WILL VOID THE WARRANTY.**

If additional information or service is needed that is not outlined in this manual, please contact your Scag Power Equipment dealer. Scag dealers are trained in the latest service methods and carry a full line of Scag replacement parts.

When ordering parts, always provide the complete model number of your Striper Accessory.

All information provided in this manual is based upon information available at the time of printing. Scag Power Equipment reserves the right to make changes at any time without notice or obligation.

### 1.2 DIRECTION REFERENCE

The "Right" and "Left", "Front" and "Rear" of the machine are referenced from the operator's right and left when seated in the normal operating position and facing the forward travel direction.

### 1.3 SAFETY AND OPERATING INSTRUCTIONS

**NOTE -**

*To avoid personal injury, it is imperative that all safety instructions be observed.*

1. Read this operator's manual and the operator's manual that is supplied with the machine this attachment is used on.

A replacement manual is available from your authorized Scag Service Dealer or by contacting: Scag Power Equipment, Service Department at P.O. Box 152, Mayville, WI 53050. You may also contact us through our website at [www.scag.com](http://www.scag.com). The manual for this accessory can be downloaded by using the model or use the contact form to make your request. Please indicate the complete model of your Scag Accessory when requesting replacement manuals.

## WARNING

**Do not operate without discharge chute, mulch kit, operator controlled discharge chute (OCDC), or entire grass catcher installed.**

2. Before removing the Striper Accessory, disengage the mower, stop the engine and wait for all movement to stop.
3. **ALWAYS** turn the engine **OFF**, remove the key and wait for all movement to stop before servicing or cleaning the mower or the grass catcher.
4. Do not modify or alter any component of the Striper Accessory or mower.
5. Do not allow any passengers to ride on the mower or any attachments.

### ASSEMBLY INFORMATION

#### 2.1 ASSEMBLY

**- NOTE -**

Use the illustrated parts list as a part number reference when following the assembly instructions.

**-IMPORTANT-**

When installing this Striper Accessory on a machine (excluding SZL36), one of the following Installation Kits must be used during installation.

- SZL-48/52 - Installation Kit p/n 922Q
- \*SFZ-48/52/61 - Installation Kit p/n 921S
- \*\*SFZ, SFZP, SPZ52 - Installation Kit p/n 921T
- \*\*\*SFZ, SFZP, SPZ61 - Installation Kit p/n 921T
- SCZ-48/52 - Installation Kit p/n 921U
- SCZ / SCZII-61/72 - Installation Kit p/n 921W
- STC & STCII - Installation Kit p/n 923H
- STT & STTII - Installation Kit p/n 923H

\*Used for SFZ48/52/61 machines equipped with 20" rear drive tires.

\*\*Used for SFZ, SFZP & SPZ machines equipped with 52" decks and 22" rear drive tires.

\*\*\*Used for SFZ, SFZP & SPZ machines equipped with 61" decks and 23" rear drive tires.

1. Remove all packaging materials. Lay out the mounting hardware, mounting brackets and striper assembly for easy access. Prepare the work area making sure that it is a clean, safe environment.
2. The following assembly instructions are specific to each model this Striper Accessory is being installed on. Follow the specific instructions for your model mower.

#### 2.2 ASSEMBLY INSTRUCTIONS SZL / SFZ / SFZP / SPZ

1. Prepare the machine so there is easy and safe access to the work area. Remove the key and maintain all safety related work procedures. Always wear eye and hand protection.
2. Using a 9/16" wrench, remove the 3/8-16 x 2-1/4" hex head bolt used to secure the axle spacer to the right transaxle assembly. Be sure to retain the bolt, lockwasher and flatwasher. This hardware will be reused in step number 6. See Figure 2-1.

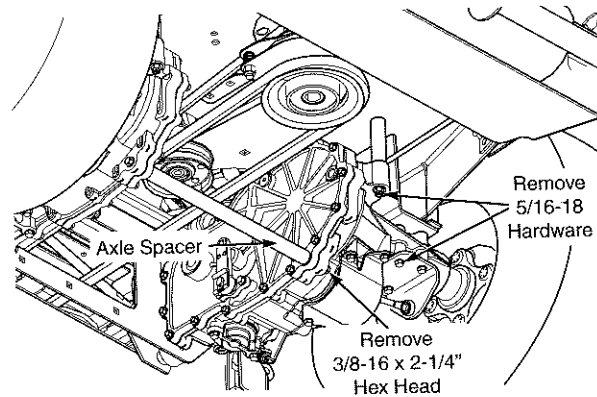

**Figure 2-1. Remove Hardware**

3. Use two 1/2" wrenches to remove the two (2) 5/16-18 hex head bolts, 5/16-18 elastic stop nuts and 5/16" flatwasher shown in Figure 2-1. Be sure to retain the flatwasher. This will be reused in step number 4.
4. Install the RH Striper Mounting Bracket as shown in Figure 2-2. Refer to the illustrated parts list following the assembly instructions in this manual to identify the 5/16-18 hex head bolts required. Secure the bracket to the machine with two (2) 5/16-18 hex head bolts and two (2) 5/16-18 elastic stop nuts included with this kit along with the 5/16" flatwasher removed in step number 3. Do not tighten hardware at this time.
5. Secure the axle spacer to the transaxle assembly and striper mounting bracket by reinstalling the 3/8-16 x 2-1/4" hex head bolt, 3/8" lockwasher and 3/8" flatwasher that were removed in step number 2. Torque this bolt to 39 ft. lbs. See Figure 2-2.

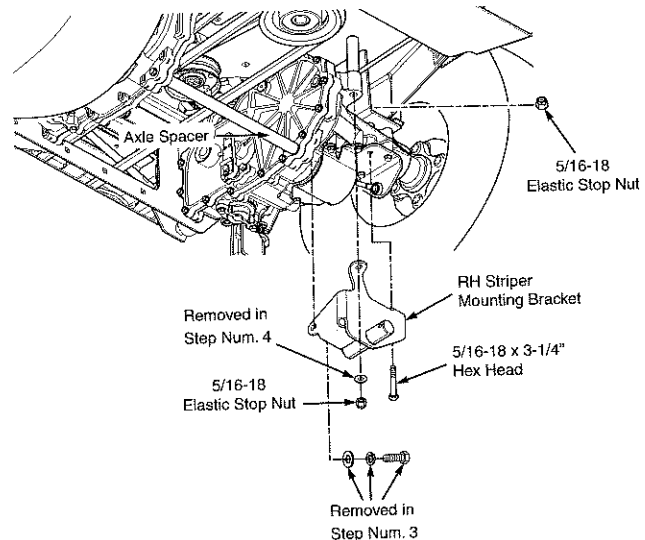

**Figure 2-2. Install RH Striper Mounting Bracket**

## Section 2

6. Using the installation procedures outlined in steps 2 thru 5 for the RH Striper Mounting Bracket, install and secure the LH Striper Mounting Bracket to the machine. Do not tighten the 5/16" mounting hardware at this time.
7. Install the Striper Roller Assembly (p/n 923F or 923M if installing on SZL36) onto the mounting brackets. See Figure 2-3.

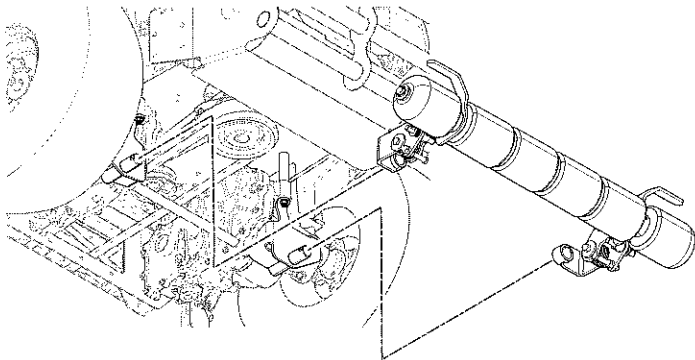

**Figure 2-3. Install Roller Assembly**

8. Torque the 5/16" mounting hardware installed in step numbers 4 and 6 to 19 ft. lbs.
9. Secure the Striper Assembly to the machine with the Quick Pins supplied. See Figure 2-4.

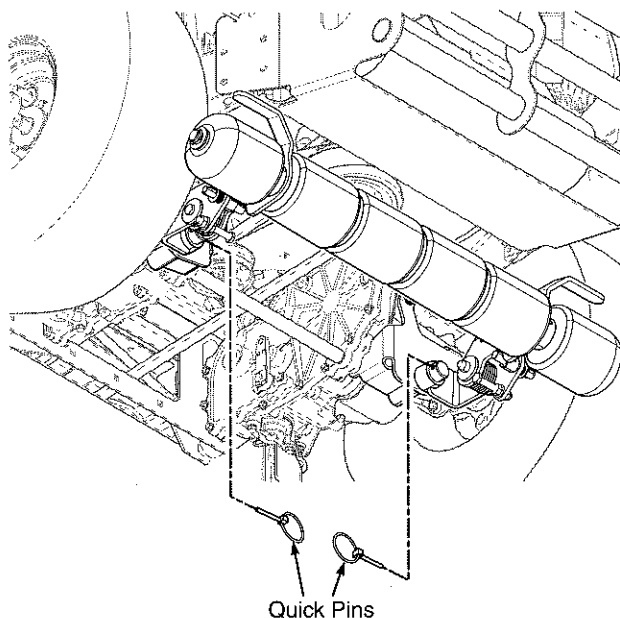

**Figure 2-4. Install Quick Pins**

10. Follow the Operating Instructions outlined in Section 3 of this manual for proper operation of this accessory.

## 2.3 ASSEMBLY INSTRUCTIONS-STC / STCII

1. Prepare the machine so there is easy and safe access to the work area. Remove the key and maintain all safety related work procedures. Always wear eye and hand protection.
2. Attach the mounting brackets to the cross bar between the wheel motor brackets using (2) Mounting Spacers, (4) u-bolts and (8) serrated flange nuts. See Figure 2-5. Do not tighten the hardware.

**-NOTE-**

*This Striper Accessory cannot be installed on an STC with a serial number below 76300001.*

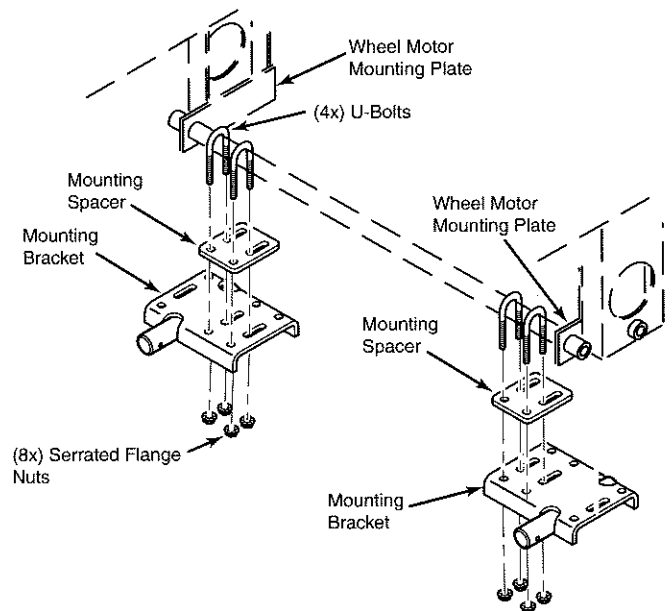
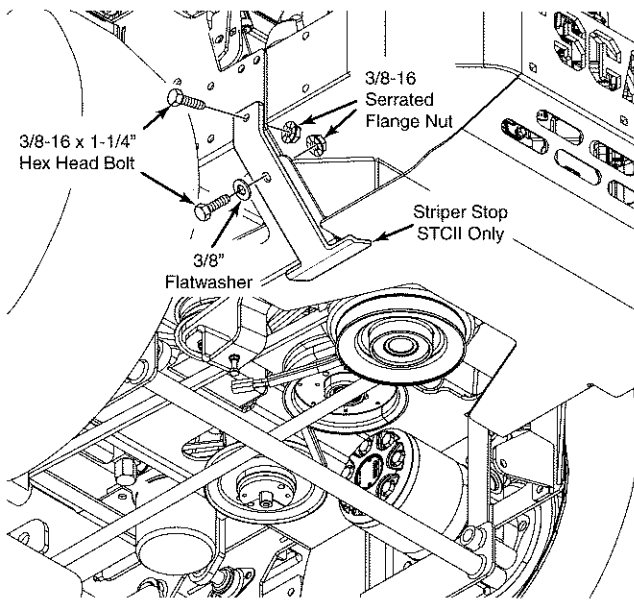

**Figure 2-5. Install Striper Mounting Brackets**

3. The edge of the mounting bracket should be under the wheel motor mounting plate for proper installation. See Figure 2-5.

- STCII Only - Install the left and right hand Striper Stop Brackets (p/n 427254) to the frame and secure with four (4) 3/8-16 x 1-1/4" bolts, two (2) 3/8" flatwashers and four (4) 3/8-16 serrated flange nuts. See Figure 2-6.

Note - Stop Brackets are not used on STC models.

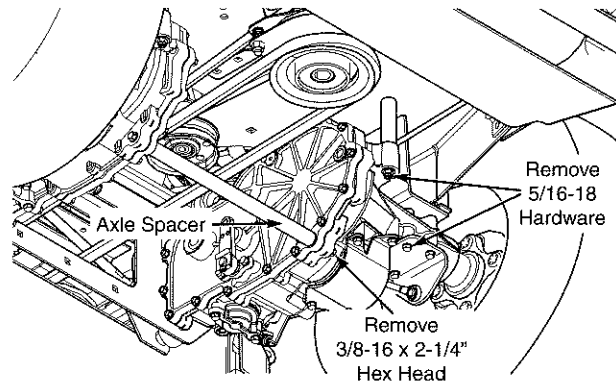

**Figure 2-6. STCII Only - Install Striper Stop Brackets  
Not Applicable to STC**

- Install the Striper Roller Assembly (p/n 923G) to the mounting brackets and secure with the quick pins.
- Once the Striper Roller Assembly is installed and secured with the quick pins, tighten the mounting hardware on both mounting brackets.
- Follow the Operating Instructions outlined in Section 3 of this manual for proper operation of this accessory.

### 2.4 ASSEMBLY INSTRUCTIONS - SCZ48/52

- Prepare the machine so there is easy and safe access to the work area. Remove the key and maintain all safety related work procedures. Always wear eye and hand protection.
- Using a 9/16" wrench, remove the 3/8-16 x 2-1/4" hex head bolt used to secure the axle spacer to the right transaxle assembly. Be sure to retain the bolt, lockwasher and flatwasher. This hardware will be reused in step number 5. See Figure 2-7.



**Figure 2-7. Remove Hardware**

- Use two 1/2" wrenches to remove the 5/16-18 x 3" hex head bolt, 5/16-18 x 5" hex head bolt, 5/16-18 elastic stop nuts and 5/16" flatwasher shown in Figure 2-7. Be sure to retain the flatwasher. This will be reused in step number 4.
- Install the RH Striper Mounting Bracket as shown in Figure 2-8. Using the new hardware provided with the Installation Kit, secure the bracket to the machine with one (1) 5/16-18 x 3-1/4" hex head bolt, one (1) 5/16-18 x 5-1/2" hex head bolt, the 5/16" flatwasher removed in step number 3 and two (2) 5/16-18 elastic stop nuts. Do not tighten this hardware at this time.
- Secure the axle spacer to the transaxle assembly and striper mounting bracket by reinstalling the 3/8-16 x 2-1/4" hex head bolt, 3/8" lockwasher and 3/8" flatwasher that were removed in step number 2. Torque this bolt to 39 ft. lbs. See Figure 2-8.



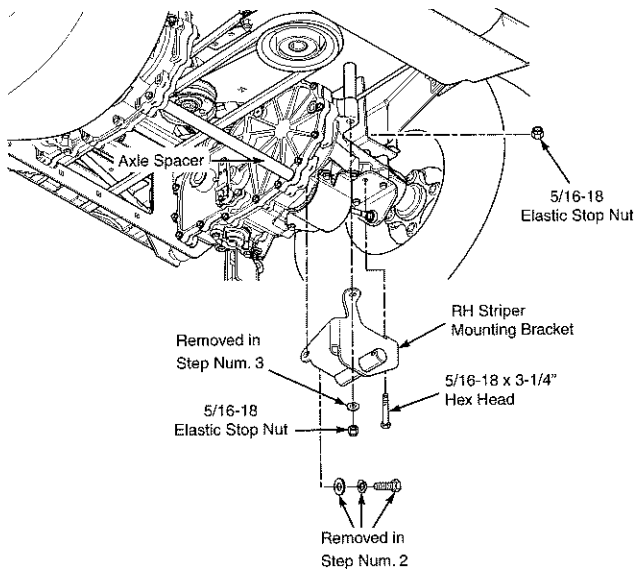

**Figure 2-8. Install RH Striper Mounting Bracket**

6. Using the installation procedures outlined in steps 2 thru 5 for the RH Striper Mounting Bracket, install and secure the LH Striper Mounting Bracket to the machine. Do not tighten the 5/16" mounting hardware at this time.
7. Install the Striper Roller Assembly (p/n 923F) onto the mounting brackets. See Figure 2-9.

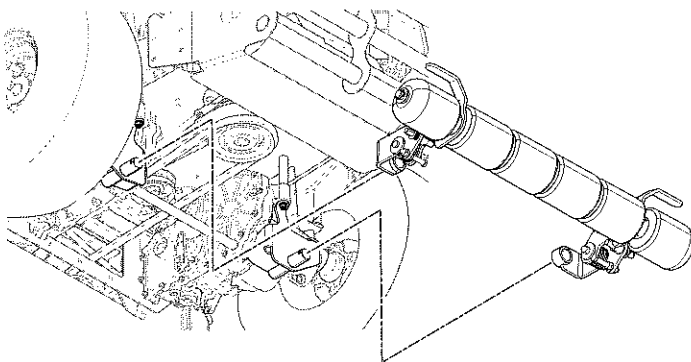

**Figure 2-9. Install Roller Assembly**

8. Torque the 5/16" mounting hardware installed in step numbers 5 and 6 to 19 ft. lbs.
9. Secure the Striper Assembly to the machine with the Quick Pins supplied. See Figure 2-10.

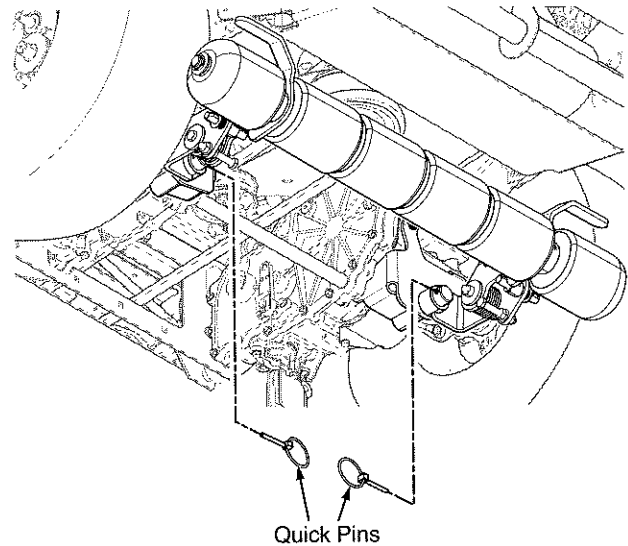
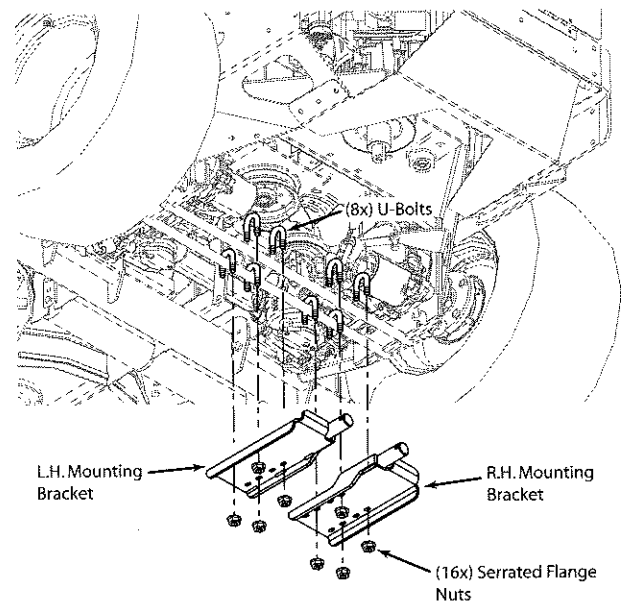

**Figure 2-10. Install Quick Pins**

10. Follow the Operating Instructions outlined in Section 3 of this manual for proper operation of this accessory.

**2.5 ASSEMBLY INSTRUCTIONS - SCZ / SCZII 61/72**

1. Prepare the machine so there is easy and safe access to the work area. Remove the key and maintain all safety related work procedures. Always wear eye and hand protection.
2. Attach the mounting brackets to the double cross bar between the hydraulic axle mounting plates using (8) u-bolts and (16) serrated flange nuts. See Figure 2-11. Do not tighten the hardware.



**Figure 2-11. Mounting Bracket Install**

- Slide the mounting brackets outward to the edge of the axle motor mounting plates. Do not tighten the hardware. See Figure 2-12.

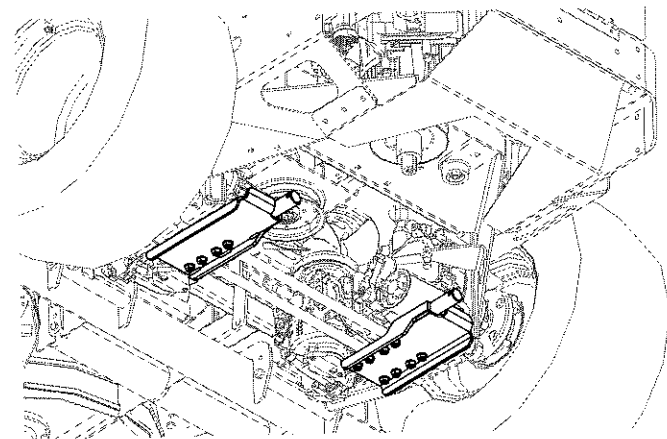
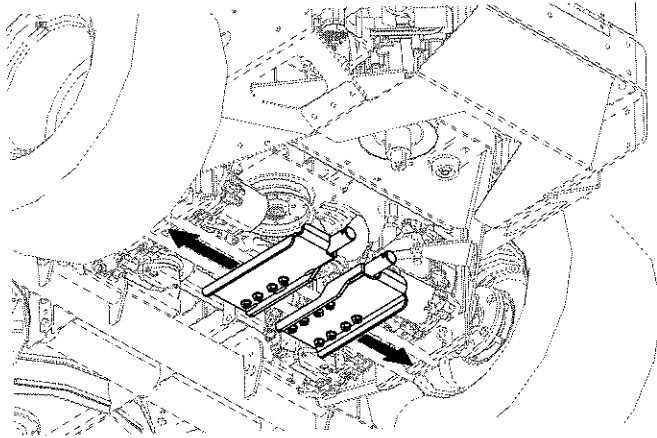

**Figure 2-12. Mounting Bracket Position**

- Install the Striper Roller Assembly (p/n 923G) to the mounting brackets and secure with the quick pins. See Figure 2-13.

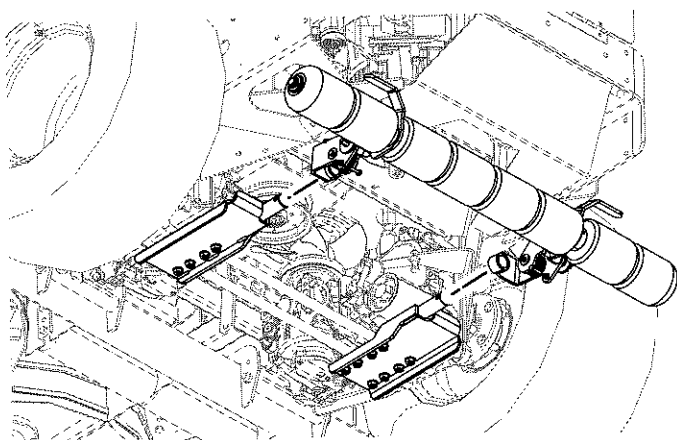

**Figure 2-13. Install Roller Assembly**

- Once the Striper Roller Assembly is installed and secure, tighten the mounting hardware on both mounting brackets.
- Follow the Operating Instructions outlined in Section 3 of this manual for proper operation of this accessory.

### 2.6 ASSEMBLY INSTRUCTIONS - STT / STTII

- Prepare the machine so there is easy and safe access to the work area. Remove the key and maintain all safety related work procedures. Always wear eye and hand protection.
- Attach the mounting brackets to the cross bar between the wheel motor brackets using (4) u-bolts and (8) serrated flange nuts. See Figure 2-14. Do not tighten the hardware.

**-NOTE-**

*If the Tiger Striper is installed on an STT with a serial number below 7219999, part number 423966 mounting spacer will need to be installed between the mounting bracket and cross bar. See Figure 2-14.*

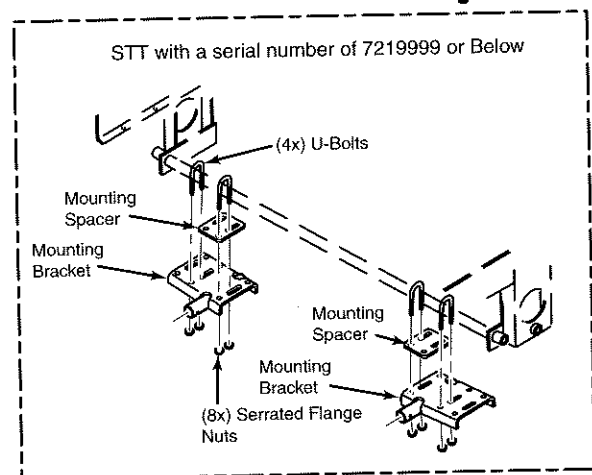
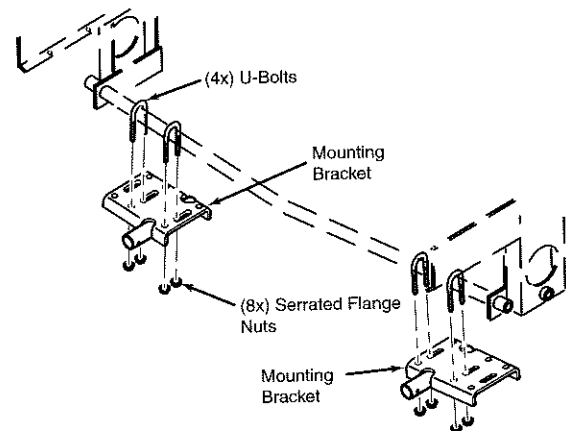

**Figure 2-14. Mounting Bracket Install**

3. The edge of the mounting bracket should be under the wheel motor mounting plate for proper installation. See Figure 2-14.
4. STT Only - Install the left and right hand Striper Stop Brackets (p/n 423953 & p/n 423954) to the frame and secure with (4) 3/8-16 x 1" bolts and (4) elastic stop nuts. See Figure 2-15.

Note - Stop Brackets are not used on STTII models.

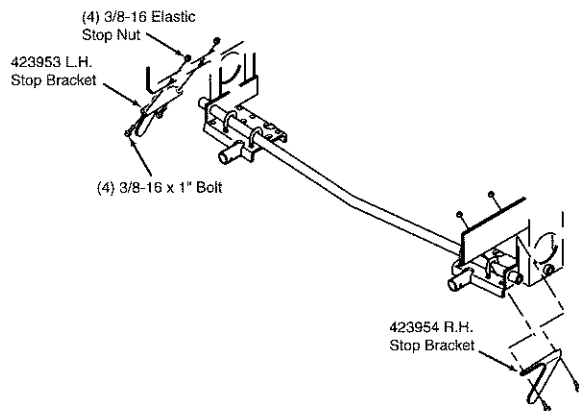

**Figure 2-15. STT Only - Install Striper Stop Brackets  
Not Applicable to STTII**

5. Install the Striper Roller Assembly (p/n 923G) to the mounting brackets and secure with the quick pins.
6. Once the Striper Roller Assembly is installed and secure, tighten the mounting hardware on both mounting brackets.
7. Follow the Operating Instructions outlined in Section 3 of this manual for proper operation of this accessory.

### OPERATING INFORMATION

#### 3.1 OPERATING INSTRUCTIONS

To operate the Striper Accessory, you will need to lower the roller to the operating position. The Striper can be easily removed or locked in the transport position whenever the machine is being transported or when striping is not needed.

1. To unlock the Striper from the transport position, lift up slightly on the handle and turn the lock until the small roll pin lines up with the slot. See Figure 3-1.

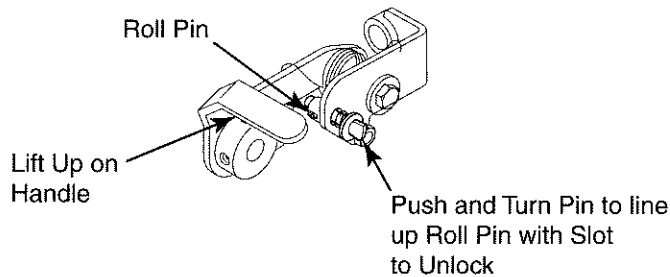

**Figure 3-1. Unlocking the Stripe Roller**

2. Repeat this procedure on the opposite side.

The Stripe Roller is now ready to operate.

#### 3.2 LAWN STRIPING

##### HOW DOES LAWN STRIPING WORK?

The "stripe" that you see on the lawn is actually light reflecting off the blades of grass. The direction in which the grass is bent determines the "light" or "dark" stripe. When the blades of grass are bent away from you, the grass appears lighter in color because light is reflecting off of the length of the blade. When the blades of grass are bent towards you, the stripe appears darker as you are looking at more of the tips of the blades (a smaller reflective surface) and the shadows under the blades of grass. Cutting a lawn in the up/down, north/south, east/west, opposing directions provides the best stripe effect.

You may find that certain grasses have a more noticeable stripe (stripe easier) than others. Cutting the grass at a different height can sometimes change the intensity of the stripe. A slightly higher cut (example: 3" versus 2.5") can provide more grass to be bent over, thus producing a more noticeable stripe. In some types of grass, this may have the opposite or no effect.

Grass that tends to be "stiff" and resists bending will not yield a stripe as well as a softer grass that bends easily.

Note that you do not need to cut the grass in order to stripe it. The roller simply needs to be in the unlocked/engaged position. You may find that when creating more advanced, overlapping striping patterns, you can complete the job faster by applying the overlaying stripes without the blades engaged.

Striping can be used to draw attention to particular landscape features. It can be used to further enhance the finished, manicured cut that your Scag mower delivers.

#### 3.3 LAWN STRIPING GUIDELINES

A stripe pattern can add richness and depth to any lawn. Here are some guidelines to help produce various patterns and to enhance your striping techniques.

##### BASIC STRIPE PATTERN:

Begin by mowing the perimeter around the property (Reference Figure 3-2). Next, mow in opposing directions through the remaining property (as shown in Figure 3-2). Take care when turning at the end of each row to prevent turf damage. A simple "Y" type turn at the end of each row will reduce the chance of turf damage while setting the mower up for the next row to be mowed.

Finish the job by mowing the perimeter again. This will remove any stripe pattern irregularities left from turning at the end of each row and delivers a finished look.

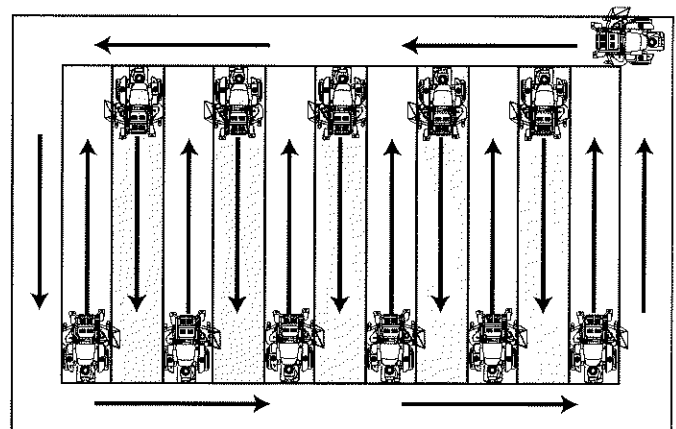

**Figure 3-2. Basic Stripe Pattern**

## Section 3

### CHECKERBOARD" PATTERN:

Begin by mowing the perimeter around the property (Reference Figure ). Next, mow in opposing directions (North and South or East and West) through the remaining portion of the property (as shown in Figure 3-3). Take care when turning at the end of each row to prevent turf damage. A simple "Y" type turn at the end of each row will reduce the chance of turf damage while setting the mower up for the next row to be mowed.

Now, travel in the opposite direction of the original mowing pattern (if you were mowing North and South, now mow East and West, etc). Reference Figure 3-3.

Finish the job by mowing the perimeter again. This will remove any stripe pattern irregularities left from turning at the end of each row and delivers a finished look.

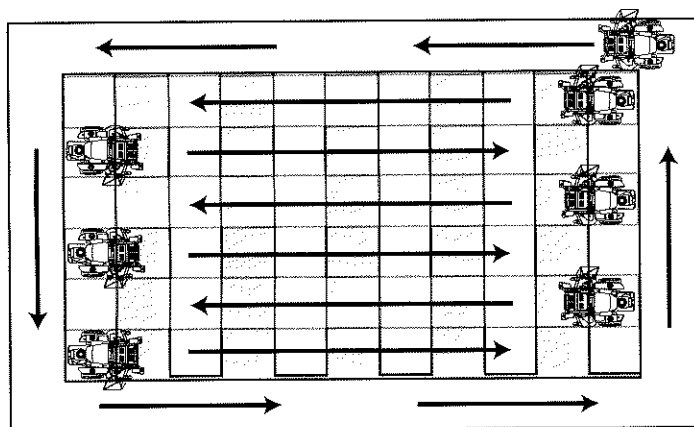

Figure 3-3. Checkerboard Pattern

### "DIAGONAL OR CRISS-CROSS" PATTERN:

This pattern is achieved using the same techniques as the "Checkerboard" pattern. Simply apply the stripes in a diagonal direction. See Figure 3-4.

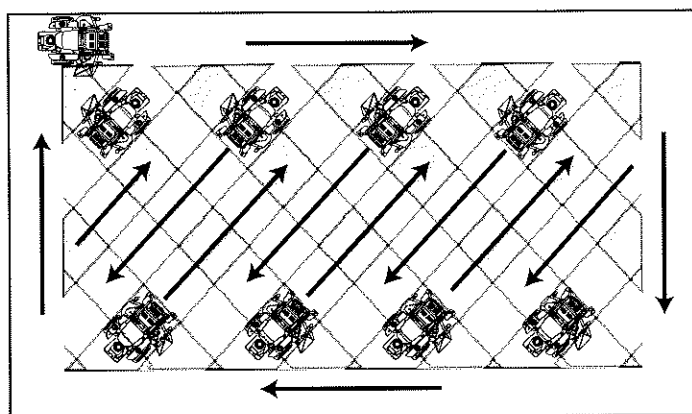

Figure 3-4. Diagonal Pattern

### 3.4 REMOVING THE STRIPE ROLLER

The Stripe Roller can be easily removed whenever the machine is being transported or when striping is not needed. To remove the Striper, follow the instructions below.

#### - NOTE -

*The Stripe Roller is removed the same way for all models. For pictorial clarity purposes, only the SCZ model is shown..*

1. Prepare the machine so there is easy and safe access to the work area. Remove the key and maintain all safety related work procedures. Always wear eye and hand protection.
2. Lock the Stripe Roller up in the transport position by lifting upward on the handle, push and turn the lock pin 90 degrees. The small roll pin must be out of the slot in the bracket to lock in the transport position. See Figure 3-5.

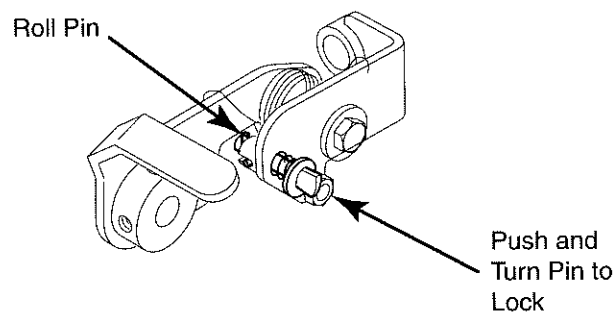
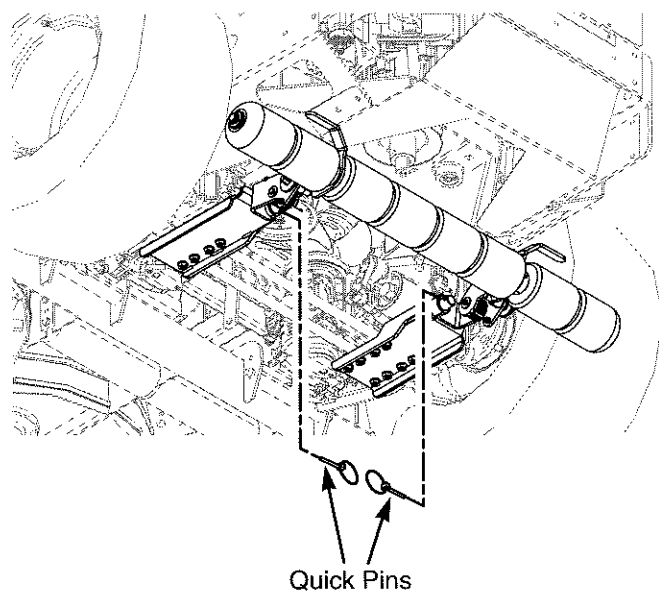

Figure 3-5. Locking Roller in Transport Position

3. Repeat on opposite side.
4. Once the Stripe Roller is locked in the transport position, remove the quick pins securing the Stripe Roller to the mounting brackets. See Figure 3-6.



**Figure 3-6. Removing Stripe Roller**

5. Slide the Stripe Roller off of the mounting brackets.
6. To install the Stripe Roller, slide the assembly on to the mounting brackets and reinstall the quick pins. Once the Stripe Roller has been reinstalled, follow Section 3.1 Operating Instructions for proper operation.

---

**ILLUSTRATED PARTS LIST**

### SZL36 STRIPER ASSEMBLY

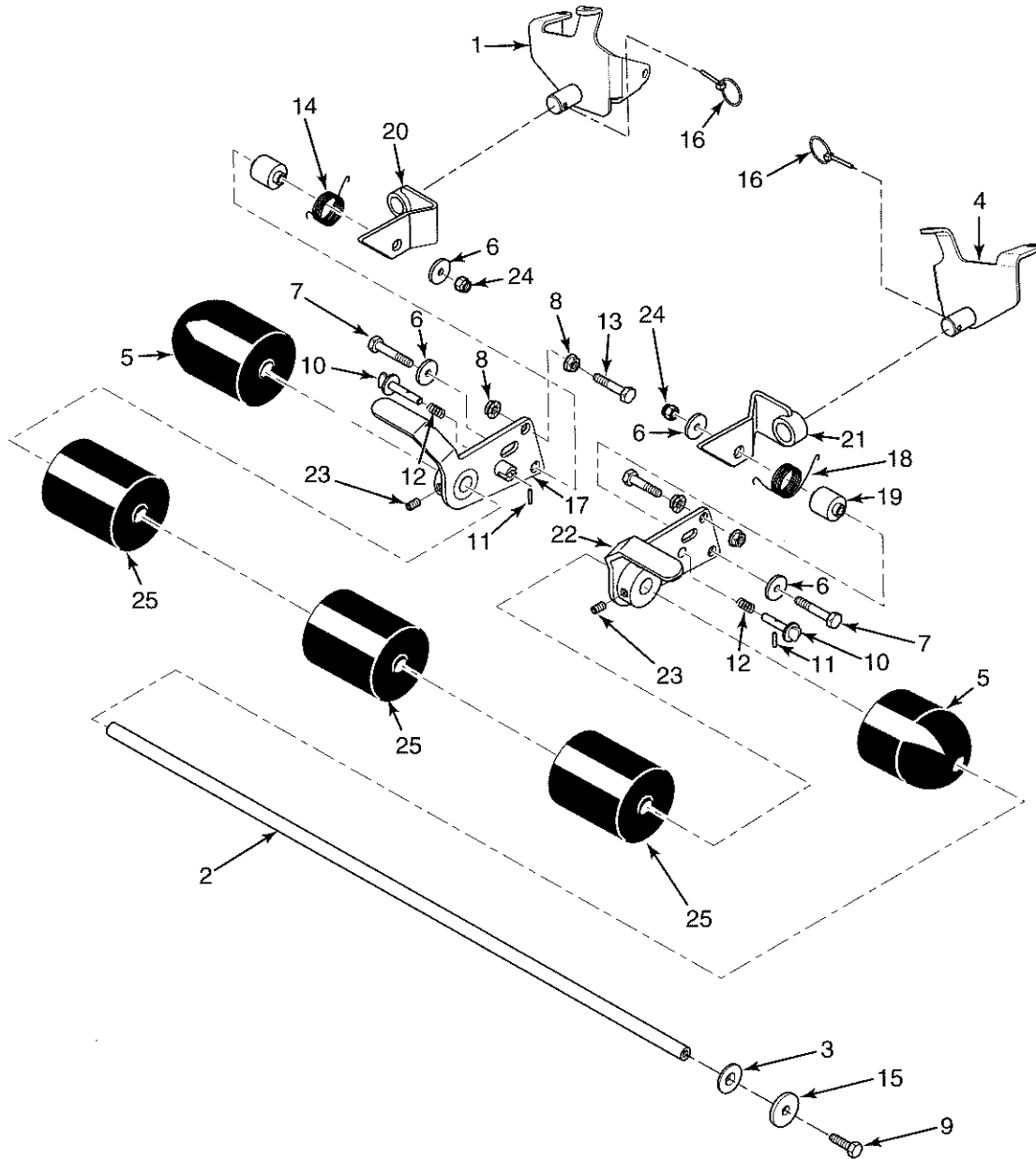

2018 SZL36-TS Exploded View\_Rev.01



## SZL36 STRIPER ASSEMBLY

Ref. No.	Part Number	Description
1	452857	Mounting Bracket Weldment, Striper - LH
2	431042	Roller Shaft
3	04042-03	Flatwasher, 3/4-.812 X 1-3/8 X .100
4	452858	Mounting Bracket Weldment, Striper - RH
5	485770	Wheel, Striper End
6	04041-11	Flatwasher, 3/8-.406 x 1-1-1/2 x 7 Gauge
7	04001-22	Bolt, Hex Head 3/8-16 x 2-3/4"
8	04019-04	Nut, Serrated Flange 3/8-16
9	04107-07	Bolt, Hex Head 5/16-18 x 1" (Special Lock)
10	461777	Pin, Lift Latch
11	04060-10	Pin, Slotted Spring 5/32" x 7/8"
12	482896	Spring, Lock Pin
13	04001-31	Bolt, Hex Head 3/8-16 x 2-1/2"
14	482894	Spring, Torsion LH
15	04041-11	Flatwasher, 3/8-.406 X 1-1/2 x 7 Gauge
16	04066-02	Quick Pin, .188 Dia.
17	451739	Hinge Weldment, LH
18	482895	Spring, Torsion RH
19	43648	Hub, Striper
20	451741	Pivot Weldment, LH
21	451742	Pivot Weldment, RH
22	451740	Hinge Weldment, RH
23	04012-06	Set Screw, 3/8-16 x 1/2"
24	04021-09	Nut, Elastic Stop 3/8-16
25	485769	Wheel, Striper

### SZL / \*SFZ - 48/52/61 STRIPER ASSEMBLY

\*SFZ Machines Equipped With 20" Rear Drive Tires  
SZL - All Models

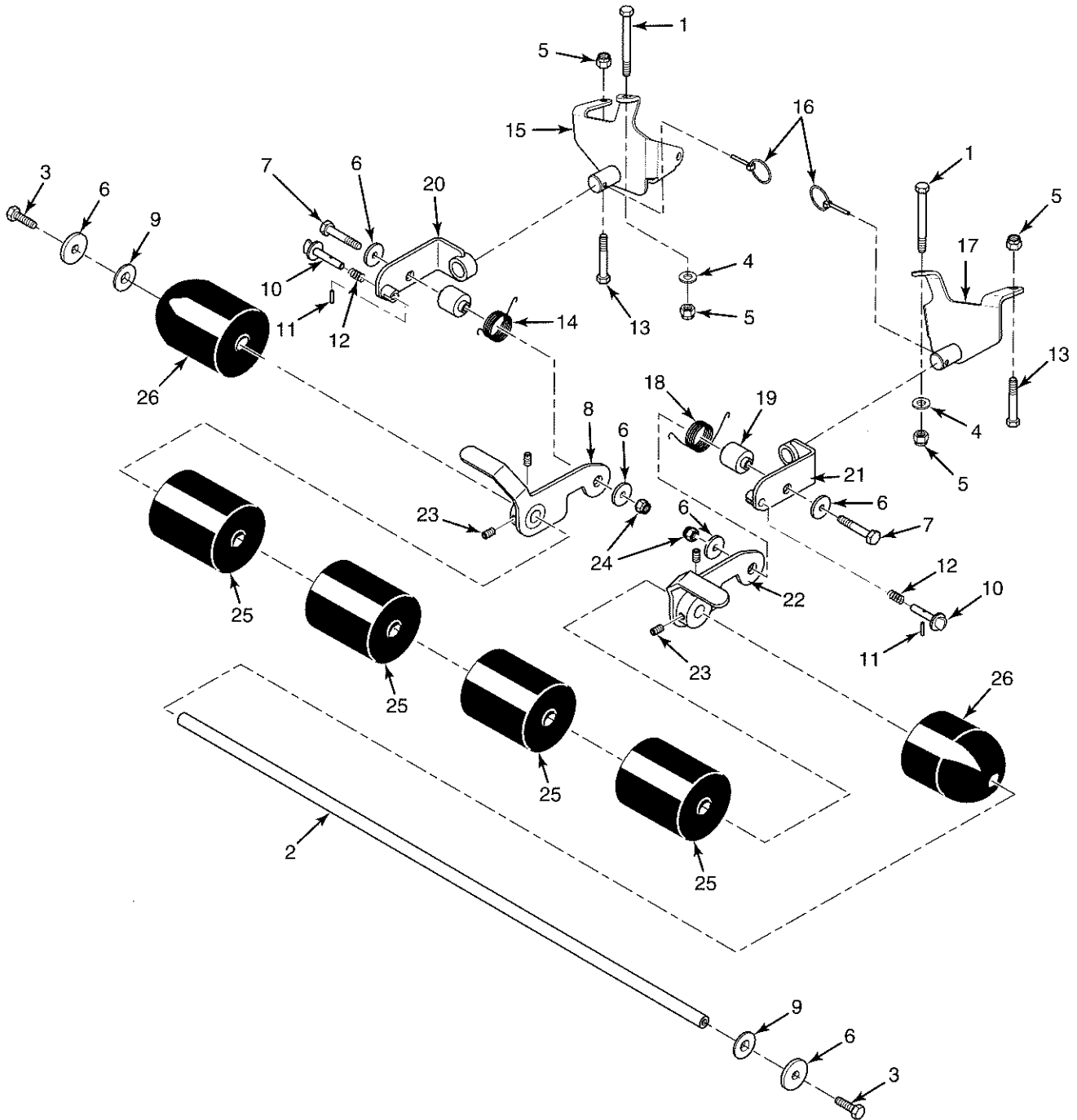

SFZ Striper Exploded View\_03475

**SZL / \*SFZ - 48/52/61 STRIPER ASSEMBLY**  
**\*SFZ Machines Equipped With 20" Rear Drive Tires**  
**SZL - All Models**

Ref. No.	Part Number	Description
1	04001-53	Bolt, Hex Head 5/16-18 x 2-1/2" - SZL
	04001-126	Bolt, Hex Head 5/16-18 x 5-1/2" - SFZ
2	431031	Roller Shaft
3	04107-07	Bolt, Hex Head 3/8-16 x 1" (Special Lock)
4	04040-15	Flatwasher, 5/16-.378 x .875 x .083
5	04021-10	Nut, Elastic Stop 5/16-18
6	04041-11	Flatwasher, 3/8-.406 x 1-1-1/2 x 7 Gauge
7	04001-22	Bolt, Hex Head 3/8-16 x 2-3/4"
8	453228	Hinge Weldment, LH
9	04042-03	Flatwasher, 3/4-.812 x 1-3/8 x .100
10	461777	Pin, Lift Latch
11	04060-10	Pin, Slotted Spring 5/32" x 7/8"
12	482896	Spring, Lock Pin
13	04001-92	Bolt, Hex Head 5/16-18 x 3-1/4"
14	482894	Spring, Torsion LH
15	452668	Mounting Bracket Weldment, LH - SZL
	451951	Mounting Bracket Weldment, LH - SFZ
16	04066-02	Quick Pin, .188 Dia.
17	452669	Mounting Bracket Weldment, RH - SZL
	451952	Mounting Bracket Weldment, RH - SFZ
18	482895	Spring, Torsion RH
19	43648	Hub, Striper
20	453230	Pivot Weldment, LH
21	453231	Pivot Weldment, RH
22	453229	Hinge Weldment, RH
23	04012-06	Set Screw, 3/8-16 x 1/2"
24	04021-09	Nut, Elastic Stop 3/8-16
25	485769	Wheel, Striper
26	485770	Wheel, Striper End

**\*SFZ / SFZP / SPZ STRIPER ASSEMBLY**  
**\*SFZ52 Machines Equipped With 22" Rear Drive Tires**  
**\*SFZ61 Machines Equipped With 23" Rear Drive Tires**  
**SFZP & SPZ - All Models**

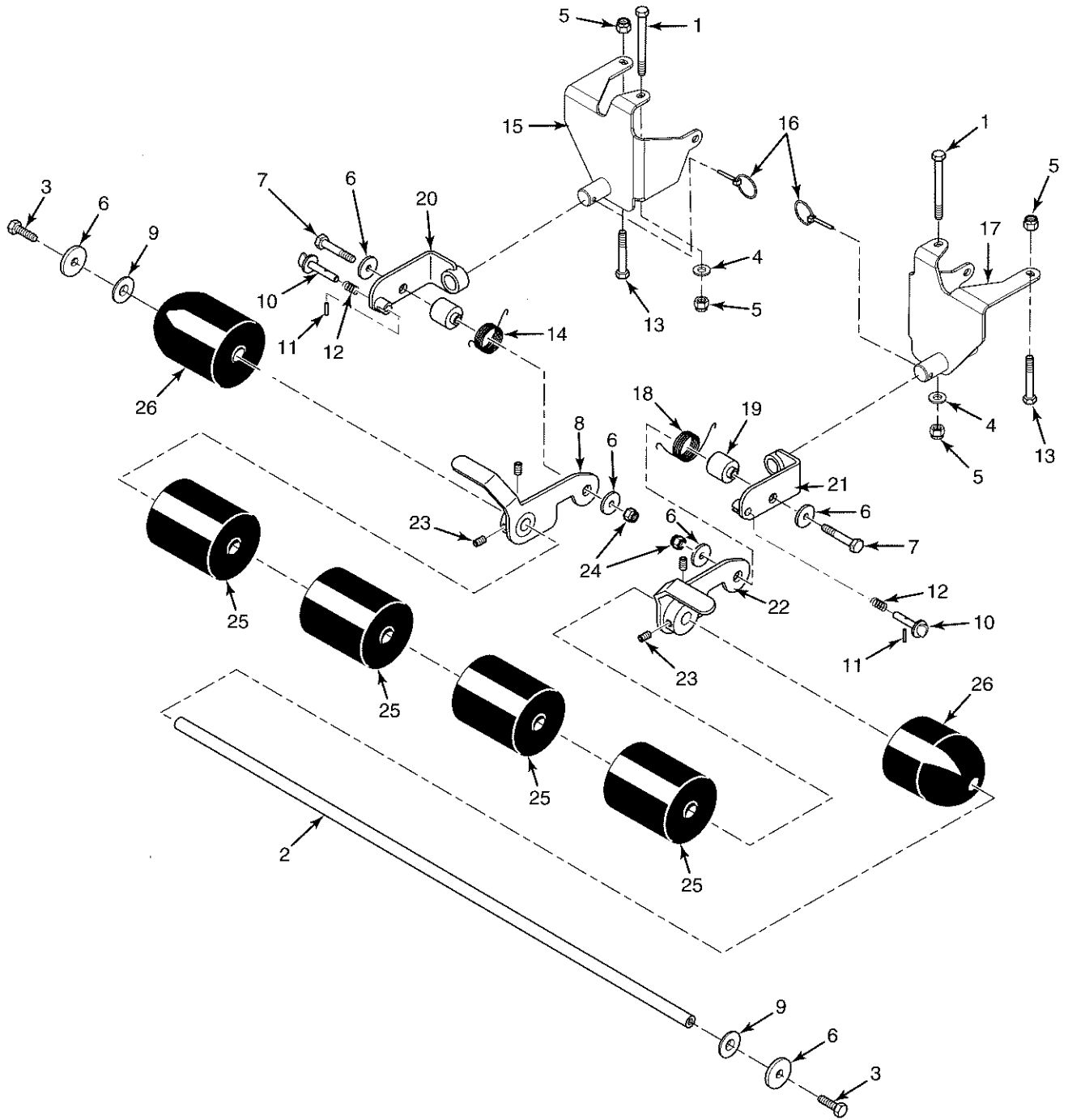

SFZ61 Striper Exploded View\_03475

**\*SFZ / SFZP / SPZ STRIPER ASSEMBLY**  
**\*SFZ52 Machines Equipped With 22" Rear Drive Tires**  
**\*SFZ61 Machines Equipped With 23" Rear Drive Tires**  
**SFZP & SPZ - All Models**

Ref. No.	Part Number	Description
1	04001-96	Bolt, Hex Head 5/16-18 x 4-1/2"
2	431031	Roller Shaft
3	04107-07	Bolt, Hex Head 3/8-16 x 1" (Special Lock)
4	04040-15	Flatwasher, 5/16-.378 x .875 x .083
5	04021-10	Nut, Elastic Stop 5/16-18
6	04041-11	Flatwasher, 3/8-.406 x 1-1/2" 7 Gauge
7	04001-22	Bolt, Hex Head 3/8-16 x 2-3/4"
8	453228	Hinge Weldment, LH
9	04042-03	Flatwasher, 3/4-.812 x 1-3/8 x .100
10	461777	Pin, Lift Latch
11	04060-10	Pin, Slotted Spring 5/32" x 7/8"
12	482896	Spring, Lock Pin
13	04001-92	Bolt, Hex Head 5/16-18 x 3-1/4"
14	482894	Spring, Torsion LH
15	452350	Mounting Bracket Weldment, LH
16	04066-02	Quick Pin, .188 Dia.
17	452351	Mounting Bracket Weldment, RH
18	482895	Spring, Torsion RH
19	43648	Hub, Striper
20	453230	Pivot Weldment, LH
21	453231	Pivot Weldment, RH
22	453229	Hinge Weldment, RH
23	04012-06	Set Screw, 3/8-16 x 1/2"
24	04021-09	Nut, Elastic Stop 3/8-16
25	485769	Wheel, Striper
26	485770	Wheel, Striper End

### STC / STCII / STWC STRIPER ASSEMBLY

STC - Models Above Serial Number 7630001

STCII - All Models

STWC - All Models

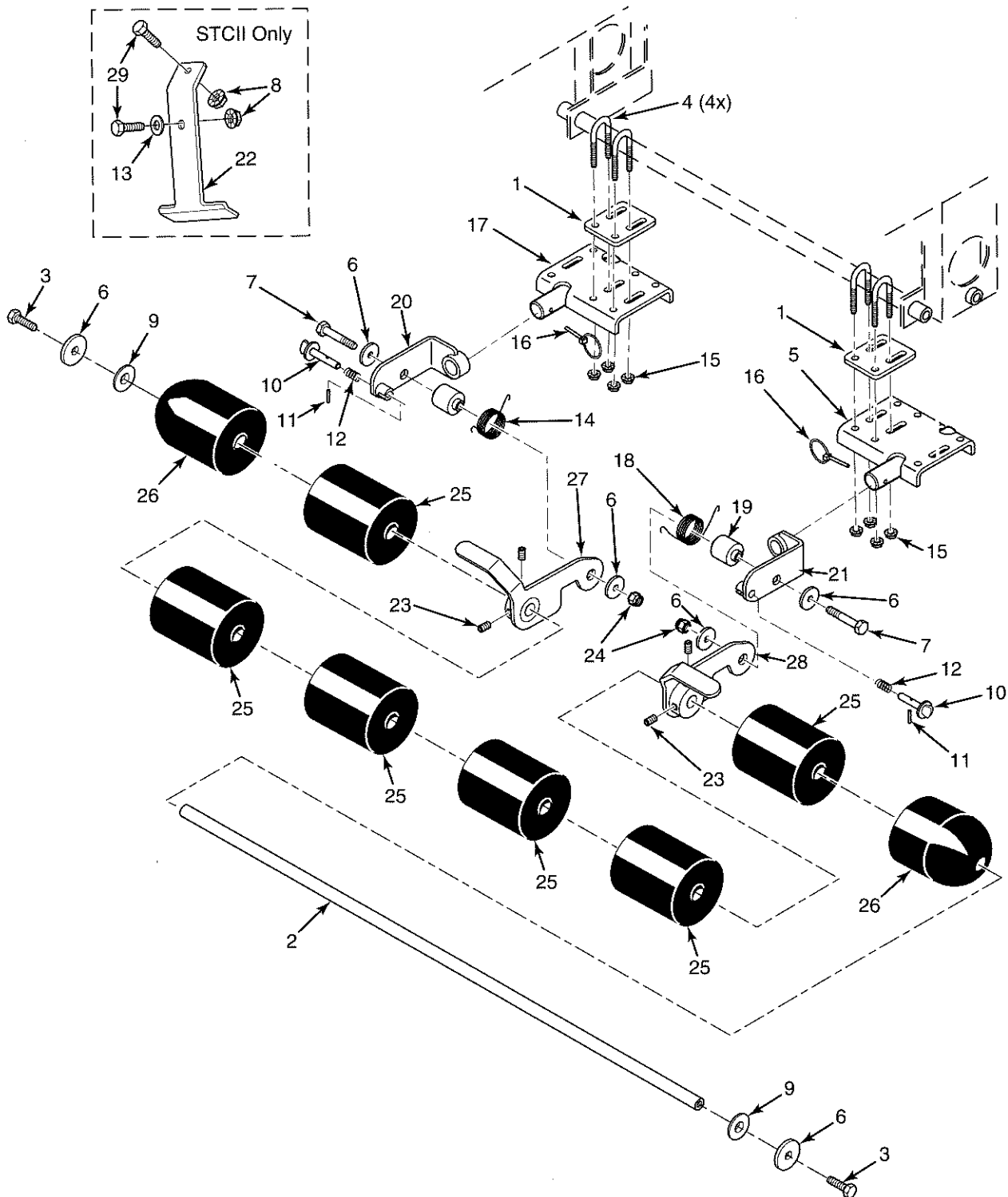

STC-TS Exploded View\_03475

## STC / STCII / STWC STRIPER ASSEMBLY

STC - Models Above Serial Number 7630001

STCII - All Models

STWC - All Models

Ref. No.	Part Number	Description
1	423966	Spacer, Striper Mounting
2	431032	Roller Shaft
3	04107-07	Bolt, Hex Head 3/8-16 x 1" (Special Lock)
4	04100-01	U-Bolt, 5/16-18 x 1"
5	452839	Mounting Bracket Weldment, LH. <b>**LH Bracket is used on the Right Side for models listed above</b>
6	04041-11	Flatwasher, 3/8-.406 x 1-1/2" 7 Gauge
7	04001-22	Bolt, Hex Head 3/8-16 x 2-3/4"
8	04019-04	Nut, Serrated Flange 3/8-16
9	04042-03	Flatwasher, 3/4-.812 x 1-3/8 x .100
10	461777	Pin, Lift Latch
11	04060-01	Pin, Slotted Spring .156 x 3/4"
12	482896	Spring, Lock Pin
13	04041-07	Flatwasher, 3/8-.391 x .938 x .105
14	482894	Spring, Torsion L.H.
15	04019-03	Nut, Serrated Flange 5/16-18
16	04066-02	Quick Pin, .188 Dia.
17	452840	Mounting Bracket Weldment, R.H. <b>**RH Bracket is used on the Left Side for models listed above</b>
18	482895	Spring, Torsion R.H.
19	43648	Hub, Striper
20	453230	Pivot Weldment, LH
21	453231	Pivot Weldment, RH
22	427254	Stop, Striper (STCII Only)
23	04012-06	Set Screw, 3/8-16 x 1/2"
24	04021-09	Nut, Elastic Stop 3/8-16
25	485769	Wheel, Striper
26	485770	Wheel, Striper End
27	453228	Hinge Weldment, LH
28	453229	Hinge Weldment, RH
29	04001-32	Bolt, Hex Head 3/8-16 x 1-1/4"

### SCZ - 48/52 STRIPER ASSEMBLY

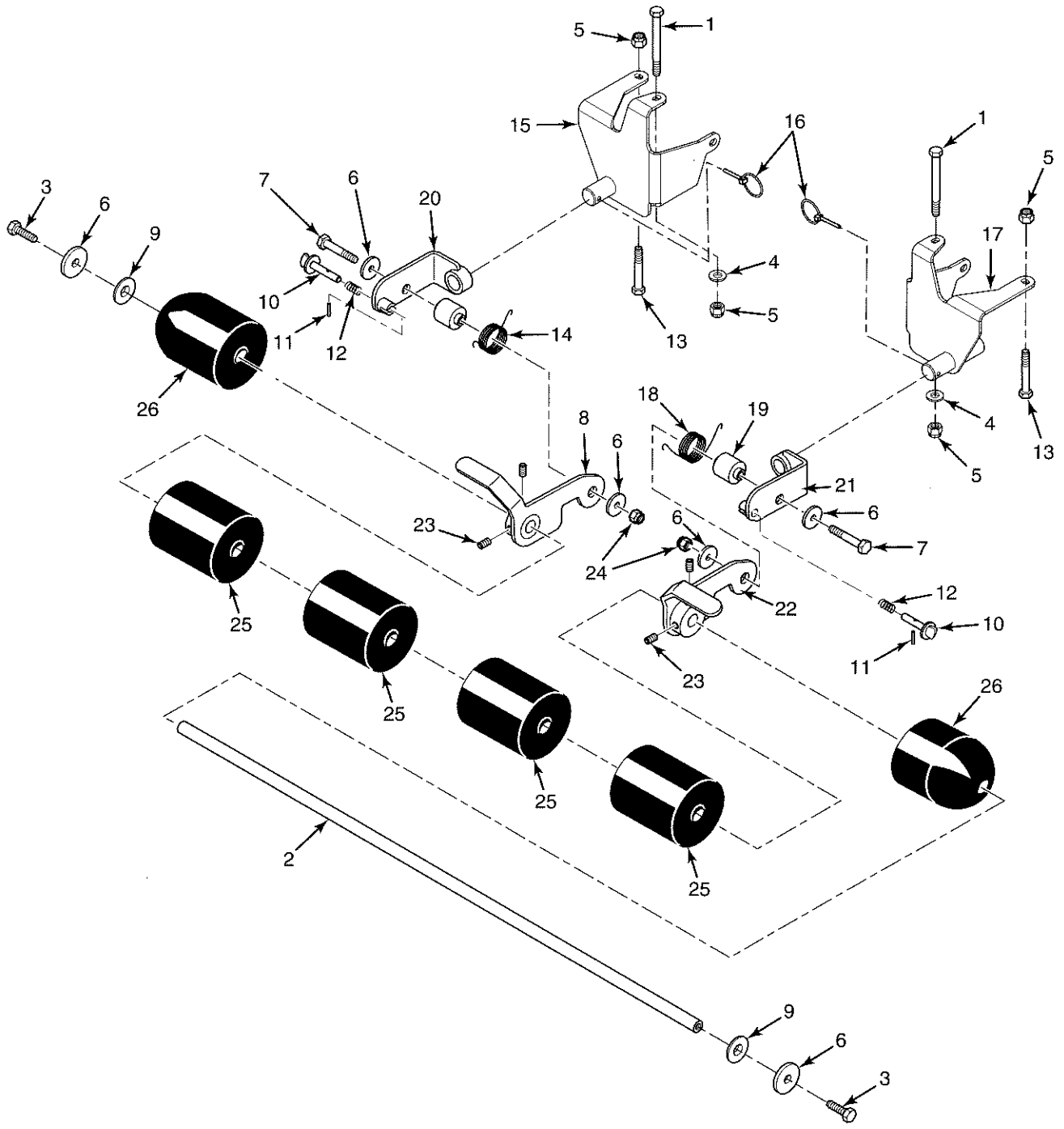

SCZ48/52 Striper Exploded View\_03475



## SCZ - 48/52 STRIPER ASSEMBLY

Ref. No.	Part Number	Description
1	04001-126	Bolt, Hex Head 5/16-18 x 5-1/2"
2	431031	Roller Shaft
3	04107-07	Bolt, Hex Head 3/8-16 x 1" (Special Lock)
4	04040-15	Flatwasher, 5/16-.378 x .875 x .083
5	04021-10	Nut, Elastic Stop 5/16-18
6	04041-11	Flatwasher, 3/8-.406 x 1-1/2" 7 Gauge
7	04001-22	Bolt, Hex Head 3/8-16 x 2-3/4"
8	453228	Hinge Weldment, LH
9	04042-03	Flatwasher, 3/4-.812 x 1-3/8 x .100
10	461777	Pin, Lift Latch
11	04060-10	Pin, Slotted Spring 5/32" x 7/8"
12	482896	Spring, Lock Pin
13	04001-92	Bolt, Hex Head 5/16-18 x 3-1/4"
14	482894	Spring, Torsion LH
15	452352	Mounting Bracket Weldment, LH - SCZ-48/52
16	04066-02	Quick Pin, .188 Dia.
17	452353	Mounting Bracket Weldment, RH - SCZ-48/52
18	482895	Spring, Torsion RH
19	43648	Hub, Striper
20	453230	Pivot Weldment, LH
21	453231	Pivot Weldment, RH
22	453229	Hinge Weldment, RH
23	04012-06	Set Screw, 3/8-16 x 1/2"
24	04021-09	Nut, Elastic Stop 3/8-16
25	485769	Wheel, Striper
26	485770	Wheel, Striper End

### SCZ / SCZII - 61/72 STRIPER ASSEMBLY

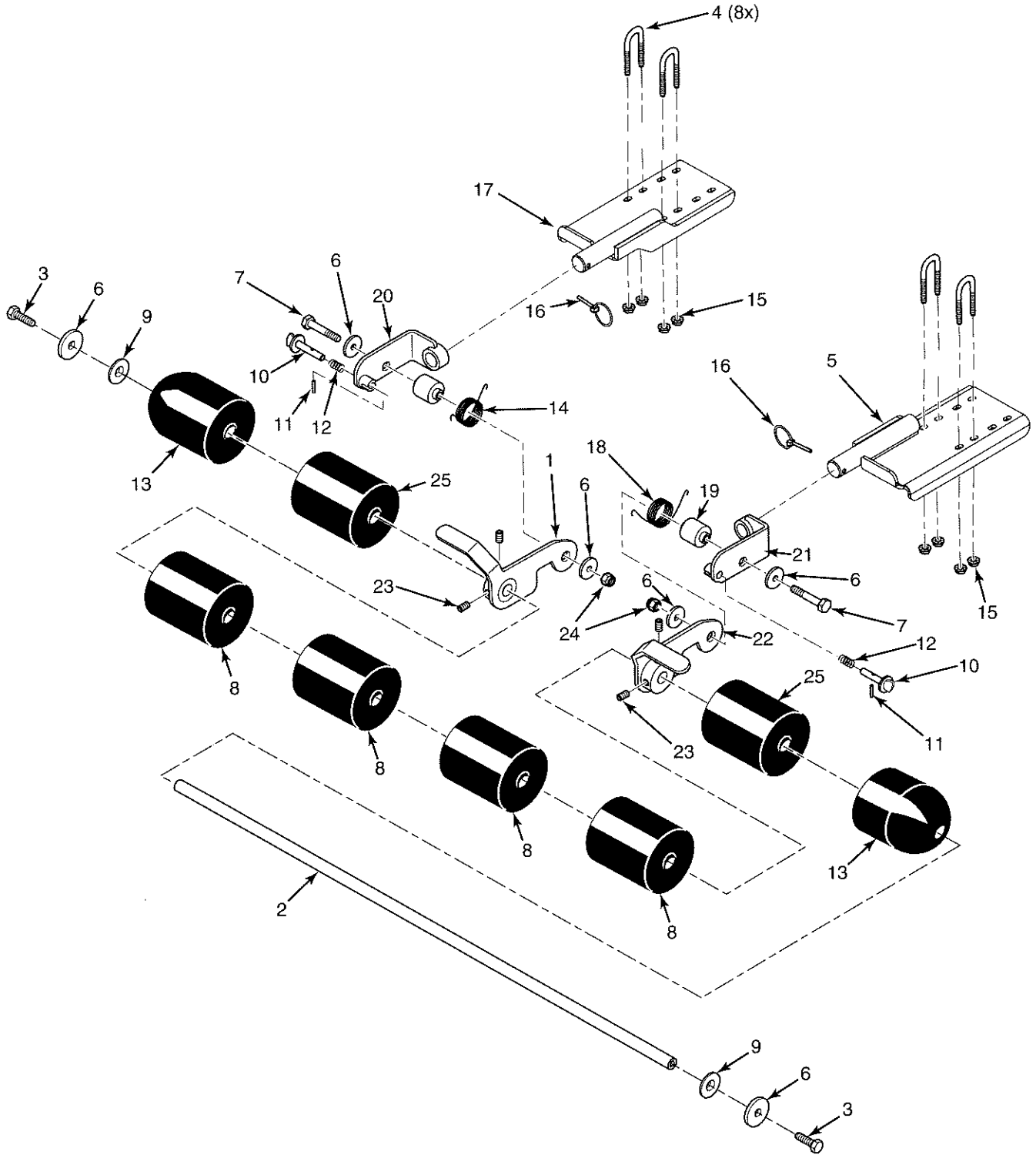

SCZ-TS Exploded View\_03475

## SCZ / SCZII - 61/72 STRIPER ASSEMBLY

Ref. No.	Part Number	Description
1	453228	Hinge Weldment, LH
2	431032	Roller Shaft
3	04107-07	Bolt, Hex Head 3/8-16 x 1" (Special Lock)
4	04100-05	U-Bolt, 1/4-20 x 3/4"
5	452177	Mounting Bracket Weldment, SCZ LH.
6	04041-11	Flatwasher, 3/8-.406 x 1-1/2" 7 Gauge
7	04001-22	Bolt, Hex Head 3/8-16 x 2-3/4"
8	485769	Wheel, Striper
9	04042-03	Flatwasher, 3/4-.812 x 1-3/8 x .100
10	461777	Pin, Lift Latch
11	04060-01	Pin, Slotted Spring .156 x 3/4"
12	482896	Spring, Lock Pin
13	485770	Wheel, Striper End
14	482894	Spring, Torsion L.H.
15	04019-02	Nut, Serrated Flange 1/4-20
16	04066-02	Quick Pin, .188 Dia.
17	452178	Mounting Bracket Weldment, SCZ R.H.
18	482895	Spring, Torsion R.H.
19	43648	Hub, Striper
20	453230	Pivot Weldment, LH
21	453231	Pivot Weldment, RH
22	453229	Hinge Weldment, RH
23	04012-06	Set Screw, 3/8-16 x 1/2"
24	04021-09	Nut, Elastic Stop 3/8-16

### STT / STTII STRIPER ASSEMBLY

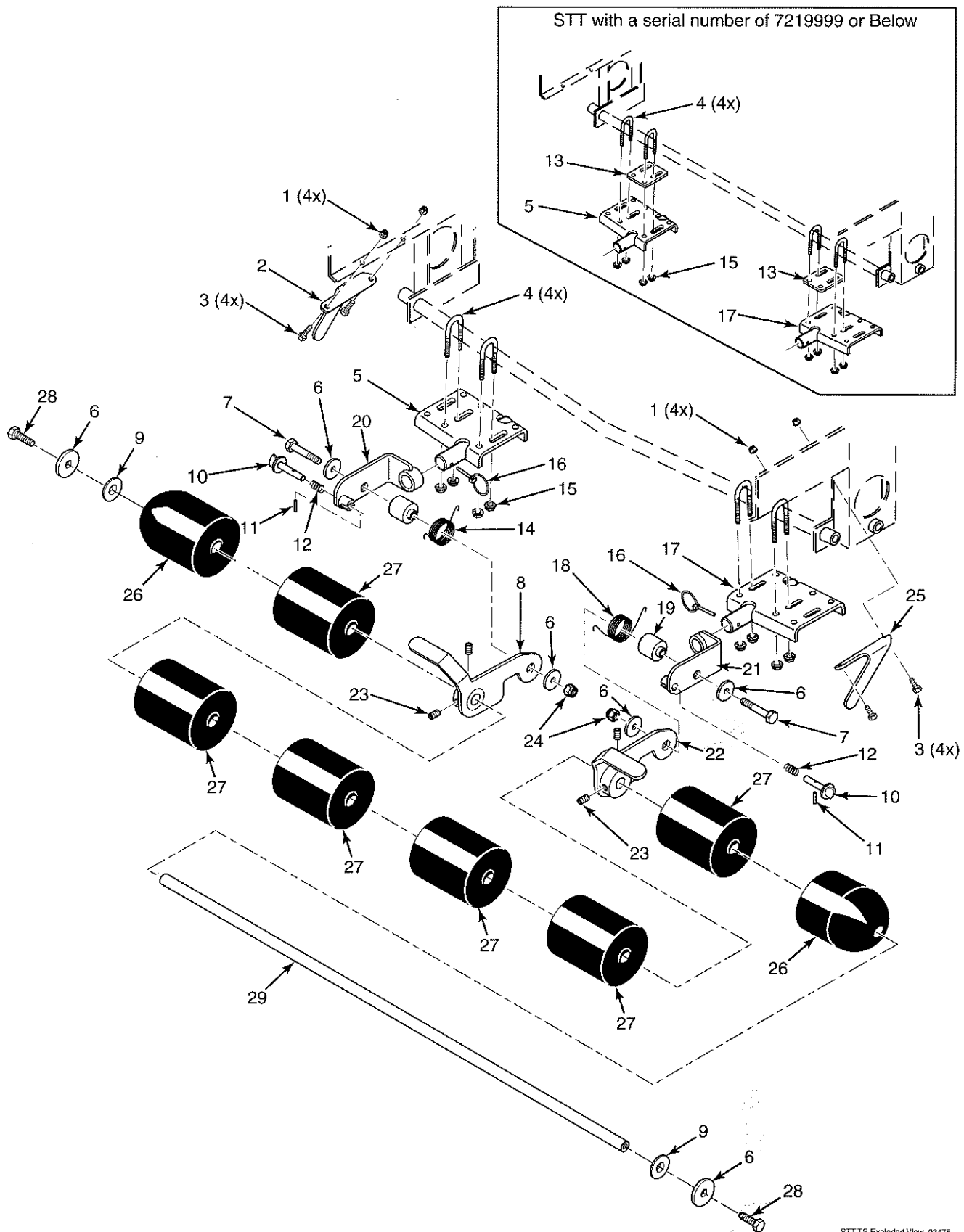

## STT / STTII STRIPER ASSEMBLY

Ref. No.	Part Number	Description
1	04021-09	Nut, Elastic Stop 3/8-16
2	423953	Striper Stop, L.H. - STT Only
3	04001-19	Bolt, Hex Head 3/8-16 x 1"
4	04100-01	U-Bolt, 5/16-18 x 1"
5	452839	Mounting Bracket Weldment, LH.
6	04041-11	Flatwasher, 3/8-.406 x 1-1/2" 7 Gauge
7	04001-22	Bolt, Hex Head 3/8-16 x 2-3/4"
8	453228	Hinge Weldment, LH
9	04042-03	Flatwasher, 3/4-.812 x 1-3/8 x .100
10	461777	Pin, Lift Latch
11	04060-01	Pin, Slotted Spring .156 x 3/4"
12	482896	Spring, Lock Pin
13	423966	Spacer, Striper Mounting
14	482894	Spring, Torsion L.H.
15	04019-03	Nut, Serrated Flange 5/16-18
16	04066-02	Quick Pin, .188 Dia.
17	452840	Mounting Bracket Weldment, R.H.
18	482895	Spring, Torsion R.H.
19	43648	Hub, Striper
20	453230	Pivot Weldment, LH
21	453231	Pivot Weldment, RH
22	453229	Hinge Weldment, RH
23	04012-06	Set Screw, 3/8-16 x 1/2"
24	04021-09	Nut, Elastic Stop 3/8-16
25	423954	Striper Stop, R.H. - STT Only
26	485770	Wheel, Striper End
27	485769	Wheel, Striper
28	04107-07	Bolt, Hex Head 3/8-16 x 1" (Special Lock)
29	431032	Roller Shaft



## LIMITED WARRANTY- COMMERCIAL ACCESSORY

---

Any part of the Scag commercial accessory manufactured by Scag and found, in the reasonable judgment of Scag, to be defective in material or workmanship, will be repaired or replaced by an Authorized Scag Service Dealer without charge for parts and labor.

The Scag accessory, including any defective part, must be returned to an Authorized Scag Service Dealer within the warranty period. The expense of delivering the accessory to the dealer for warranty work and the expense of returning it back to the owner after repair or replacement will be paid for by the owner. Scag's responsibility in respect to claims is limited to making the required repairs or replacements, and no claim of breach of warranty shall be cause for cancellation or rescission of the contract of sale of any Scag machine. Proof of purchase will be required by the dealer to substantiate any warranty claim. All warranty work must be performed by an Authorized Scag Service Dealer.

This warranty is limited to 90 days from the date of original retail purchase for any Scag accessory that is used for commercial purposes, or any other income-producing purpose including rental use.

The warranty for the grass catcher blower assemblies (excluding the belt) is limited to 1-year from the date of original retail purchase. 90 Days for rental use.

This warranty does not cover any accessory that has been subject to misuse, neglect, negligence, or accident, or that has been operated in any way contrary to the operating instructions as specified in the Operator's Manual. The warranty does not apply to any damage to the accessory that is the result of improper maintenance, or to any accessory or parts that have not been assembled or installed as specified in the Operator's Manual.

The warranty does not cover any accessory that has been altered or modified. In addition, the warranty does not extend to repairs made necessary by normal wear, or by the use of parts or accessories which, in the reasonable judgment of Scag, are either incompatible with the Scag mower or adversely affect its operation, performance or durability. This warranty does not cover engines and electric starters, which are warranted separately by their manufacturer.

Scag Power Equipment reserves the right to change or improve the design of any accessory without assuming any obligation to modify any accessory previously manufactured.

All other implied warranties are limited in duration to the 90 day warranty period. Accordingly, any such implied warranties including merchantability, fitness for a particular purpose, or otherwise, are disclaimed in their entirety after the expiration of the appropriate ninety day warranty period. Scag's obligation under this warranty is strictly and exclusively limited to the repair or replacement of defective parts and Scag does not assume or authorize anyone to assume for them any other obligation. Some states do not allow limitations on how long an implied warranty lasts, so the above limitation may not apply to you.

Scag assumes no responsibility for incidental, consequential or other damages including, but not limited to, expense for gasoline, oil, expense of delivering the machine to an Authorized Scag Service Dealer and expense of returning it back to the owner, mechanic's travel time, telephone or telegram charges, rental of a like product during the time warranty repairs are being performed, travel, loss or damage to personal property, loss of revenue, loss of use of the mower, loss of time, or inconvenience. Some states do not allow the exclusion or limitation of incidental or consequential damages, so the above limitation or exclusion may not apply to you.

This warranty gives you specific legal rights, and you may also have other rights which vary from state to state.